

**data**video®

## Digital Video Converter

# DAC-200

## Installation Guide



<http://www.datavideo-tek.com>

Rev:140206

# Table of Contents

<b>Warnings and Precautions</b>	2
<b>Warranty</b>	4
<b>Disposal</b>	4
<b>FCC &amp; CE Certification</b> (Radio & Television Interference)	5
<b>What's in the Box</b>	7
<b>Key Features</b>	7
<b>User Interface Functions</b>	
Front panel control/connection	8
Rear panel control/connection	9
DIP switch settings	11
<b>Installation / Connections</b>	12
Connecting an analogue VCR or Camcorder to a PC / MAC NLE System	
Connecting a PC / MAC NLE System to an analogue VCR	13
<b>Operation Procedure</b>	10
<b>Specification</b>	12
<b>Service &amp; Support</b>	13

## Warnings and Precautions

1. Read all of these warnings and save them for later reference.
2. Follow all warnings and instructions marked on this unit.
3. Unplug this unit from the wall outlet before cleaning. Do not use liquid or aerosol cleaners. Use a damp cloth for cleaning.
4. Do not use this unit in or near water.
5. Do not place this unit on an unstable cart, stand, or table. The unit may fall, causing serious damage.
6. Slots and openings on the cabinet top, back, and bottom are provided for ventilation. To ensure safe and reliable operation of this unit, and to protect it from overheating, do not block or cover these openings. Do not place this unit on a bed, sofa, rug, or similar surface, as the ventilation openings on the bottom of the cabinet will be blocked. This unit should never be placed near or over a heat register or radiator. This unit should not be placed in a built-in installation unless proper ventilation is provided.
7. This product should only be operated from the type of power source indicated on the marking label of the AC adapter. If you are not sure of the type of power available, consult your Datavideo dealer or your local power company.
8. Do not allow anything to rest on the power cord. Do not locate this unit where the power cord will be walked on, rolled over, or otherwise stressed.
9. If an extension cord must be used with this unit, make sure that the total of the ampere ratings on the products plugged into the extension cord do not exceed the extension cord's rating.
10. Make sure that the total amperes of all the units that are plugged into a single wall outlet do not exceed 15 amperes.
11. Never push objects of any kind into this unit through the cabinet ventilation slots, as they may touch dangerous voltage points or short out parts that could result in risk of fire or electric shock. Never spill liquid of any kind onto or into this unit.

12. Except as specifically explained elsewhere in this manual, do not attempt to service this product yourself. Opening or removing covers that are marked “Do Not Remove” may expose you to dangerous voltage points or other risks, and will void your warranty. Refer all service issues to qualified service personnel.
13. Unplug this product from the wall outlet and refer to qualified service personnel under the following conditions:
  - a. When the power cord is damaged or frayed;
  - b. When liquid has spilled into the unit;
  - c. When the product has been exposed to rain or water;
  - d. When the product does not operate normally under normal operating conditions. Adjust only those controls that are covered by the operating instructions in this manual; improper adjustment of other controls may result in damage to the unit and may often require extensive work by a qualified technician to restore the unit to normal operation;
  - e. When the product has been dropped or the cabinet has been damaged;
  - f. When the product exhibits a distinct change in performance, indicating a need for service.

## Warranty

Datavideo warrants that the equipment it manufactures shall be free from defects in material and workmanship for a period of 12 months from the date of product purchased. If equipment fails due to such defects, Datavideo will, at its option, repair or provide a replacement for the defective part or product.

Equipment that fails after the warranty period, has been operated or installed in a manner other than that specified by Datavideo, or has been subjected to abuse or modification, will be repaired for time and material charges at the Buyer's expense. This warranty does not affect your statutory rights within the Country of purchase.

## Disposal

**For EU Customers only - WEEE Marking.**



This symbol on the product indicates that it will not be treated as household waste. It must be handed over to the applicable take-back scheme for the recycling of electrical and electronic equipment. For more detailed information about the recycling of this product, please contact your local Datavideo office.

# **RADIO & TELEVISION INTERFERENCE**

**UNITED STATES.** The equipment described in this guide generates and uses radio frequency energy. If it is not installed and used in accordance with the instructions in this guide, it may cause interference with radio and television reception.

**This equipment has been tested and found to comply with the limits for a Class B digital device, pursuant to Part 15 of the FCC Rules. These limits are designed to provide reasonable protection against harmful interference in a residential installation. This equipment generates, uses and can radiate radio frequency energy and, if not installed and used in accordance with the instructions, may cause harmful interference to radio communications. However, there is no guarantee that interference will not occur in a particular installation. If this equipment does cause harmful interference to radio or television reception, which can be determined by turning the equipment off and on, the user is encouraged to try to correct the interference by one or more of the following measures:**

- Reorient or relocate the receiving antenna.
- Increase the separation between the equipment and receiver.
- Connect the equipment into an outlet on a circuit different from that to which the receiver is connected.
- Consult the dealer or an experienced radio/TV technician for help.

If necessary, you should consult your dealer or experienced radio/television technician for additional suggestions. You may find helpful the following booklet, prepared by the Federal Communications Commission: How to Identify and Resolve Radio-TV Interference Problems. This booklet is available from the United States Government printing office, Washington, D.C. 20402. The booklet number is 004-000-00345-4.

**Note: Changes or Modifications not expressly approved by the party responsible for compliance could void the users right to operate this equipment.**

Peripheral used in conjunction with this equipment must be connected via shielded interface cables. Use of unshielded interface cables may result in interference to radio and TV reception, and may void the user's right to operate this equipment.



### **Declaration of Conformity**

Model Number: DAC-200

Trade Name: Datavideo

Responsible: Datavideo Corporation (USA)

Address: 12300-U East Washington Blvd., Whittier,  
CA 90606 USA

Telephone: (562) 696-2324

This device complies with Part 15 of the FCC Rules. Operation is subject to the following two conditions:

- (1) This device may not cause harmful interference.
- (2) This device must accept any interference received, including interference that may cause undesired operation.

## What's in the Box

The following is a packing list. If any items are missing please contact your supplying dealer as soon as possible.

- 1 x DAC-200
- 1 x AC Adapter (5V 2.0A)
- 1 x S-Video (Y/C) Cable – 4 Pin Mini Din Plug to 4 Pin Mini Din Plug
- 1 x 3 Phono Plug (RCA) to 3 Phono Plug Cable
- 1 x IEEE1394 (DV) Cable - 6 Pin Plug to 6 Pin Plug
- 1 x Quick Start Guide
- 1 x Instruction Manual

## Key Features

### **Bi-Directional DV to Analog Video Converter DV to Analog / Analog to DV**

The DAC-200 is a simple stand alone box for converting video and audio back and forth between analog and digital (DV).

Using the DAC-200 to convert analog to DV let's you maintain the quality of your analog tape without generation loss.

- Supports DV, S Video - Y/C, Composite inputs and outputs for easy conversion across platforms
- Video Comb Filter for High Quality Video
- Selectable digital audio sampling rate at 12-bit 32KHz or 16-bit 48KHz
- Selectable Audio Decoding at 32KHz, 44.1KHz and 48KHz
- Selectable 0 IRE / 7.5 IRE black level setting
- Compatible with DV (iLink), Digital 8, Video 8, Hi8, VHS, S-VHS, VHS-C and S-VHS-C formats
- Encode to or decode from the Mac environment
- FireWire In and out
- Works with PC Windows 98SE/ME/2000 and XP
- Smart DV (Pat. Pending) allows video monitoring during DV to DV Capture



# FRONT PANEL CONTROL/CONNECTION

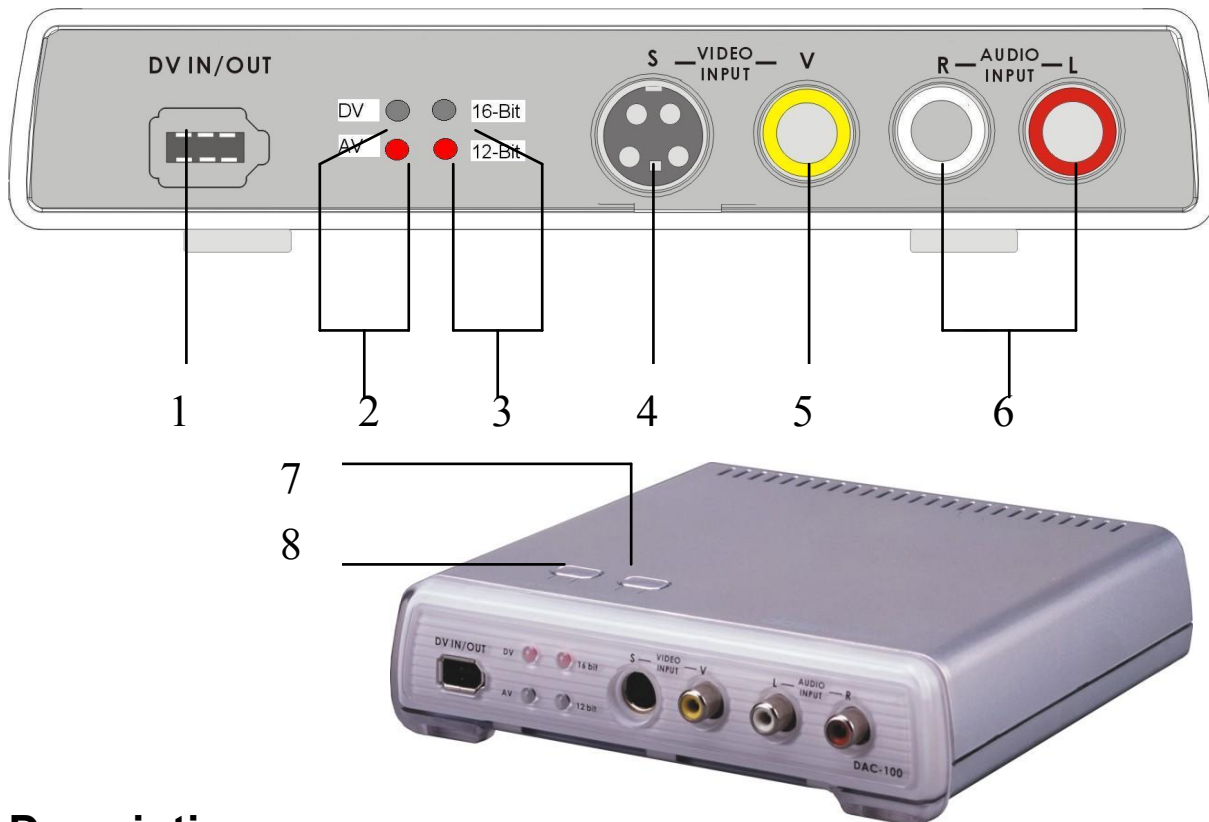

## Description:

1. 6-Pin FireWire interface for DV In/Out
2. Video source indicators for DV or AV input
3. LED indicators for Audio encoder 12-Bit or 16-Bit
4. S-Video (Y/C) input connector.
5. Composite Video input RCA connector
6. Stereo Audio input RCA connectors
7. Push button to select 12-Bit or 16-Bit Audio encoding
8. Push button to select video input source DV or AV

**Note:** Please wait 5 seconds for the LED ready status to come on after you push the video source button. The system needs a few seconds to recognize a new video source setting.

# REAR PANEL CONTROL/CONNECTION

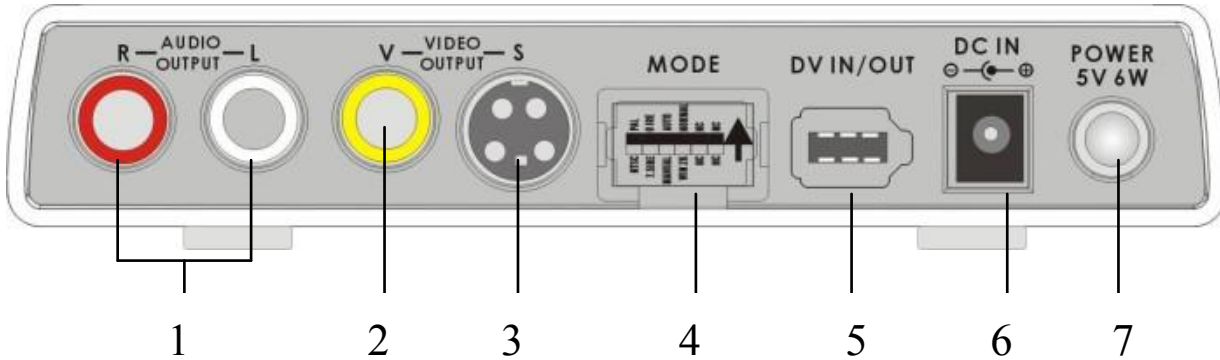

## Description:

1. Stereo Audio output Phono (RCA) connectors
2. Composite Video output Phono (RCA) connector
3. S-Video (Y/C) output connector
4. Mode DIP switch (*Reboot the DAC-200 if you change a DIP Switch*)

(See page 11 for more details)

- **S1.** PAL or NTSC (PAL-ON, NTSC-OFF)
- **S2.** 7.5 IRE / 0 IRE (0 IRE-ON, 7.5 IRE-OFF) (NTSC Only).  
**Please note:** 0 IRE is most often used in Japan. 7.5 IRE is used elsewhere.
- **S3** Locked / Unlocked Audio. On – Unlocked Audio / Off – Locked Audio
- **S4 & S5** for NTSC and PAL video system

<b>S5</b>	ON	<b>S4</b>	ON	MAC OS
<b>S5</b>	ON	<b>S4</b>	OFF	Smart DV – (Please see description on page 11)
<b>S5</b>	OFF	<b>S4</b>	ON	Windows ME / XP
<b>S5</b>	OFF	<b>S4</b>	OFF	DV Camera

- **S6.** Reserved, should always be OFF.
5. 6-Pin FireWire interface for DV In/Out
  6. DC Input Jack (+ 5VDC / 6Watts)
  7. Power Switch (**Note: Turn-on DAC-200 before booting the PC/MAC editing software.**)

## **IMPORTANT NOTICE FOR PC/MAC EDITING SYSTEMS**

The following guide lines are general advice for video editing on a computer platform. If you have purchased a computer specified for video editing it will almost certainly be set up correctly. If you are in any doubt please consult your computer reseller, or a computer technician.

1. **Shut down all resident programs** in your PC for better editing performance. Such as the Anti-Virus program, screen saver, system power management software... etc.

2. **Enable the Disk DMA function in windows to improve system HDD access performance**

There are too many non-linear editing platforms to give in-depth advise about individual set-ups. The DAC-200 should be seen by your PC/MAC as though it is a DV Camera / Recorder. If there are device control settings on your editing platform please set them to off.

Extra details of some non-linear platforms are available on line, please go to <http://www.datavideo.info/products/dac200.htm> for the latest details.

We will try to test and update system information as it becomes available, however for in-depth information about your specific NLE platform we would recommend that you contact your supplier, or the manufacturer.

## Dip Switch settings to work with Windows & MAC Operation system

The DAC-200 uses dip switches 4 and 5 to control the clocking frequency when it is converting video, if the dip switches are not configured for your operating system or type of device, a loss in video can occur. Please refer to dip switch chart below and make sure that your DAC-200 is setup correctly.

**SMART DV** is a patent pending feature that allows monitoring of the video during a DV to DV capture.

Enabling SMART DV makes the converter transparent to an NLE system, while still transcoding the live DV stream into analogue video. This enables users to monitor a live digital video feed from a DV camcorder or DV deck during capture, without any conflict. It means a huge saving of time for all video editors working with DV tape.

NTSC System (USA)  
MAC OS

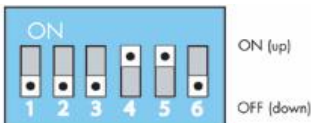

NTSC System (USA)  
Smart DV on

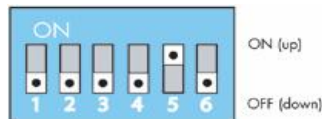

NTSC System (USA)  
Windows XP and Windows ME

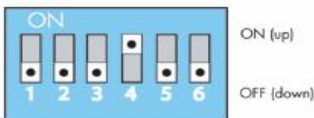

NTSC System (USA)  
Camera

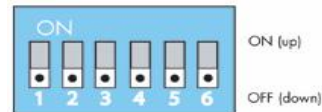

PAL System (EU)  
MAC OS

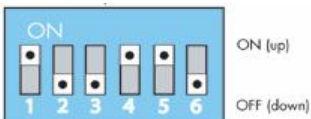

PAL System (EU)  
Smart DV on

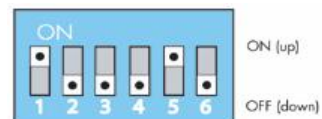

PAL System (EU)  
Windows XP and Windows ME

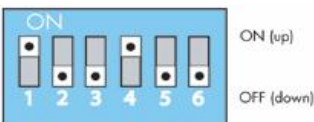

PAL System (EU)  
Camera



## Installation / Connections

There are many possible ways to connect a DAC 200 to different systems. Illustrated below are the two most common set ups, DV output from an NLE system to an analogue recorder, and Analogue output to a PC / MAC NLE system.

If your analogue device has S-Video connections available it is advisable to use them as the signal quality will be superior to composite (RCA / Phono) connections. If you are using S-Video (Y/C) connections do make sure you also connect the Red and White (RCA / Phono) connectors for audio.

Many analogue VCRs have SCART connectors, it is no problem to use these with a DAC 200 however you will need to use a SCART to 3 Phono / RCA Adaptor, available from high street electrical stores. These adaptors are available in three types, IN only, OUT only and switchable (IN and OUT), a switchable adaptor would allow the most flexibility.

### Connecting an analogue VCR or Camcorder to a PC / MAC NLE System

Connect the analogue output from the VCR or Camcorder to the inputs on the front of the DAC 200. If S-Video (Y/C) is available it is best to use it.

Connect the DV Out from the DAC 200 to the IEEE 1394 / DV In on your NLE system. Press the source button on the DAC 200 to ensure the AV light is on. Make sure your DIP switch settings are correct for your set up (see page 11)

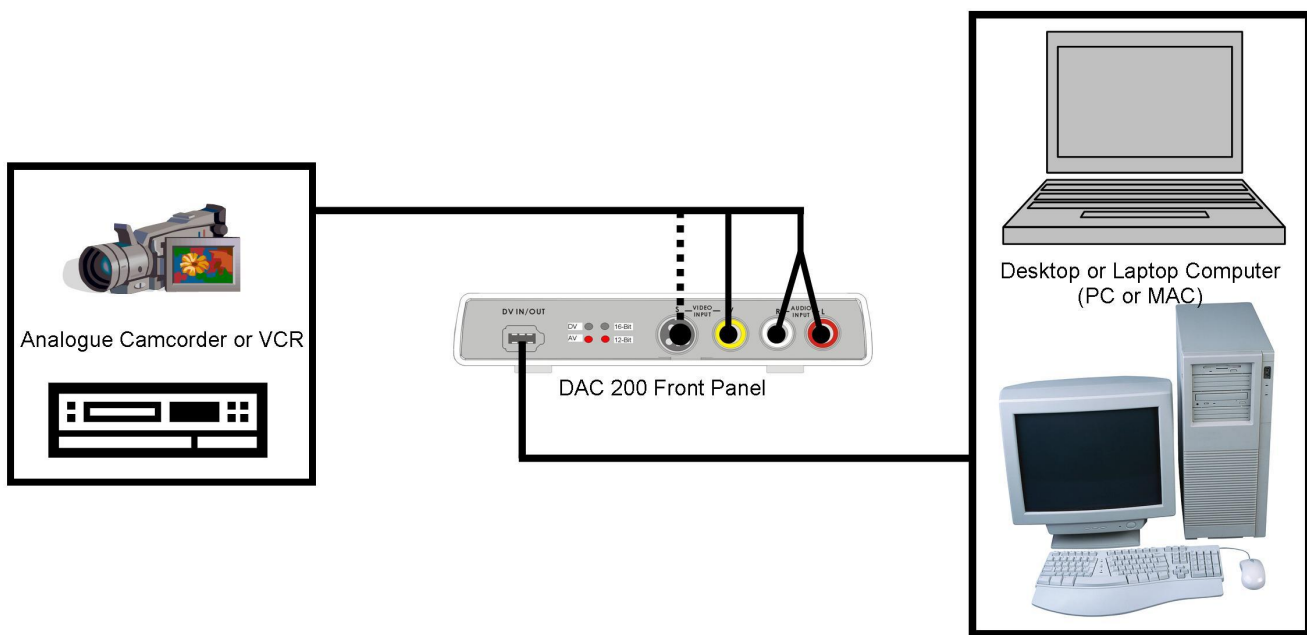

## Connecting a PC / MAC NLE System to an analogue VCR

Connect the IEEE 1394 / DV Out from your NLE system to the DV In/Out on the DAC 200. Some NLE systems have 6 Pin DV out, like the DAC 200, while others use the smaller 4 Pin connection, either type of connection will work OK.

Connect the analogue Audio and video outputs on the rear of the DAC 200 to the inputs on your record deck. If your record deck has S-Video (Y/C) available it is advisable to use it in preference to the Composite (Yellow Phono / RCA connector).

**N.B.** Please ensure that you set the input of your record deck to the appropriate setting. Some of the names used by VCR manufacturers are AUX (Auxillary), Line1, AV1, F1, EXT (External).

Check that the DAC 200 has the DV light on, if it does not press the source button.

Make sure your DIP switch settings are correct for your set up (see page 11)

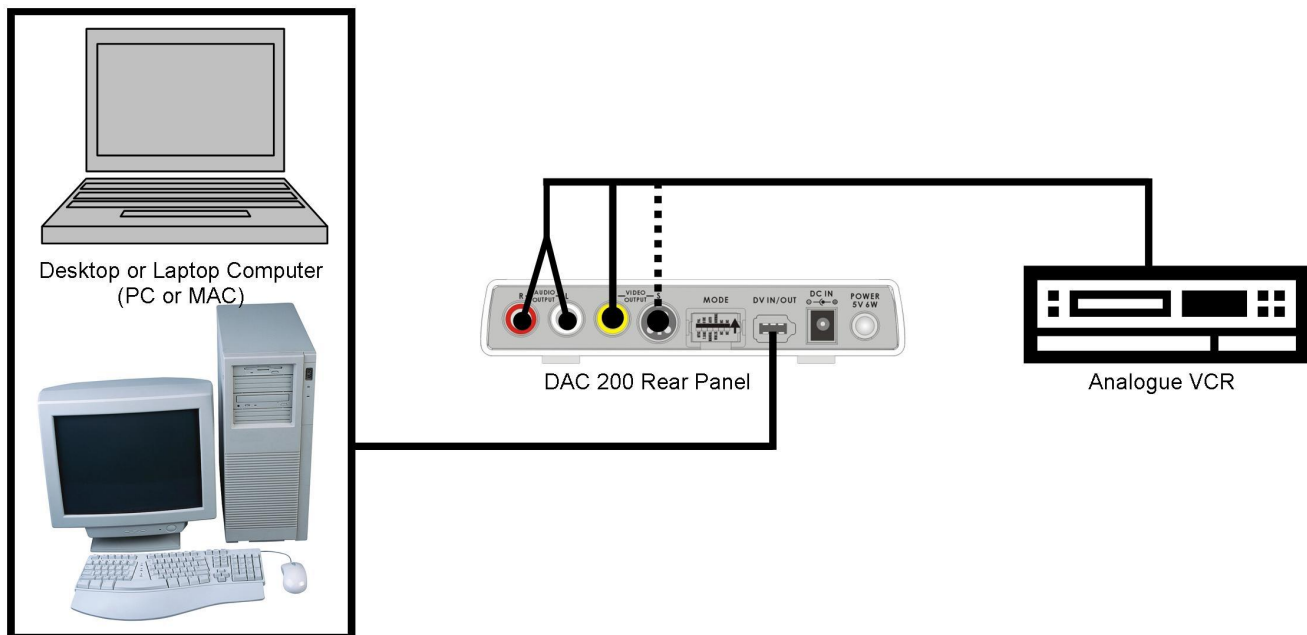

## Specifications:

### INPUTS

S-VHS sources	Y/C in: 4—pin 75 ohm DIN connector
Composite	1.0Vp-p 75ohm RCA connector
*DV (iLink) Source	Data Transfer Rate 25Mbps, PAL 4:2:0 / NTSC 4:1:1

### OUTPUTS

S-VHS Source	Y/C out 4-pin 75ohm DIN connector
Composite Video Source	1.0 Vp-p 75ohm RCA connector
Frequency Response	4.5 MHz +/- 3 dB (DV input) 20Hz~ 18KHz <3dB
DG, DP	+/- 3%, 3°
Audio Sampling Rate	12bit 32KHz and 16bit 48KHz option
Audio Freq. Response	20Hz ~ 18KHz <3dB
Audio THD	<0.2%
*DV (iLink) Source	Data Transfer Rate 25Mbps, PAL 4:2:0 / NTSC 4:1:1

### GENERAL

Power (Included)	DC 5V / 6.0W AC Adapter <b>Caution: DAC-200 requires DC 5 Volt +/- 4%, Use only Datavideo approved Power Adaptor.</b>
Ambient Temperature	32° - 131°F (0° - 55°C)
Ambient Humidity	Less than 90 %
Dimensions	6.15”(W) × 6.0”(D) × 1.6”(H) 156(W) × 150(D) × 40(H) m/m
Accessories (included)	1.8m IEEE 1394 cable (6 Pin to 6 Pin) 3 Phono to 3 Phono (RCA) cable. S-Video (Y/C) cable User's manual Quick Start Guide Power supply

\*. All the trademarks are the properties of their respective owners

## Service and Support

It is our goal to make your products ownership a satisfying experience. Our support team is available to assist you in setting up and operating your system. Please refer to our web site [www.datavideo-tek.com](http://www.datavideo-tek.com) for answers to common questions, support requests or contact your local office below.

### **Datavideo Corporation (USA)**

12300-U East Washington Blvd., Whittier, CA 90606 USA

Tel: +1 562 696 2324      [contactus@datavideo.us](mailto:contactus@datavideo.us)      [www.datavideo.us](http://www.datavideo.us)

### **Datavideo Technologies Europe BV**

Californiedreef 26 3565 BL Utrecht, The Netherlands

Tel: +31 30 261 9656      [info@datavideo.nl](mailto:info@datavideo.nl)      [www.datavideo.info](http://www.datavideo.info)

### **Datavideo UK Limited**

Unit 2 Waterside Business Park, Hadfield, Glossop, Derbyshire SK131BE UK

Tel: +44 1457 851000      [sales@datavideo.co.uk](mailto:sales@datavideo.co.uk)      [www.datavideo.info](http://www.datavideo.info)

### **Datavideo Technologies Co., Ltd.**

10F, 176 Jian-Yi Rd, Chung Ho City, Taipei Hsien, Taiwan 235

Tel: +886 2 8227 2888      [info@datavideo.com.tw](mailto:info@datavideo.com.tw)      [www.datavideo.com.tw](http://www.datavideo.com.tw)

### **Datavideo Technologies China Co.**

2F-D, 2 Lane 777, West Guangzhong Rd, Zhabei District, Shanghai, China

Tel: +86 21 5603 6599      [service@datavideo.cn](mailto:service@datavideo.cn)      [www.datavideo.cn](http://www.datavideo.cn)

### **Datavideo Technologies (S) PTE Ltd.**

No. 100, Lorong 23 Geylong, #01-03 D'Centennial Bldg, Singapore 388398

Tel: +65 6749 6866      [info@datavideo.sg](mailto:info@datavideo.sg)      [www.datavideo.info](http://www.datavideo.info)

### **Datavideo Hong Kong Limited**

G/F., 26 CROSS LANE, WANCHAI, HK

Tel: +852 2833 1981      [info@datavideohk.com](mailto:info@datavideohk.com)      [www.datavideohk.com](http://www.datavideohk.com)